

ML12M/ML16M/ML20M

MATERIAL LIFTS



- A high specification material lift, with best-in-class load capacity
- Narrow design with ultra compact reduced height mast to easily pass through a single doorway
- Robust and reliable
- Features a dual handle, shift-on-the-fly, two-speed winch for improved productivity

 **snorkel**[™]
www.snorkellifts.com

MATERIAL LIFTS

DIMENSIONS	ML12M	ML16M	ML20M
Lift height – forks up	3.8m	4.9m	6.0m
Lift height – forks down	3.3m	4.4m	5.5m
Stowed width (A)	0.77m	0.77m	0.77m
Stabiliser width (B)	1.63m	1.63m	1.63m
Stowed length	0.84m	0.88m	0.91m
Operating length (C)	1.72m	1.85m	2.1m
Stowed height (D)	1.59m	1.59m	1.59m
Fork width (outside)	0.58m	0.58m	0.58m
Fork length (E)	0.76m	0.76m	0.76m
Ground clearance	60mm	60mm	60mm

PERFORMANCE	ML12M	ML16M	ML20M
Max. load capacity (0.36m load centre)	318kg	295kg	272kg
Max. load capacity (0.61m load centre)	200kg	195kg	181kg
Max. load capacity (1.07m load centre)	84kg	79kg	80kg
Min. load height	150mm	150mm	150mm
Winch (high speed)		13.1 cranks/m	
Winch (low speed)		49.2 cranks/m	

WEIGHT	ML12M	ML16M	ML20M
Weight	120kg	135kg	151kg

LOAD CAPACITY - STANDARD FORKS

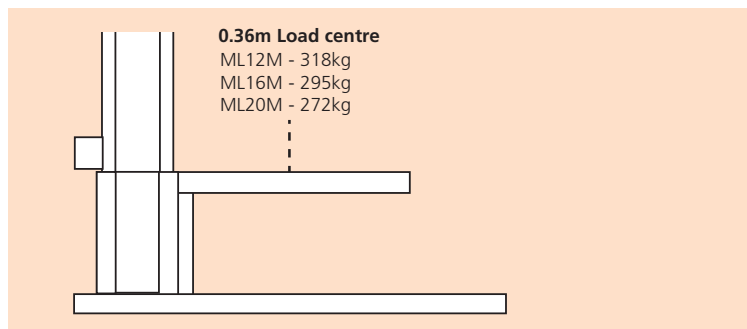

LOAD CAPACITY - EXTENDED FORKS

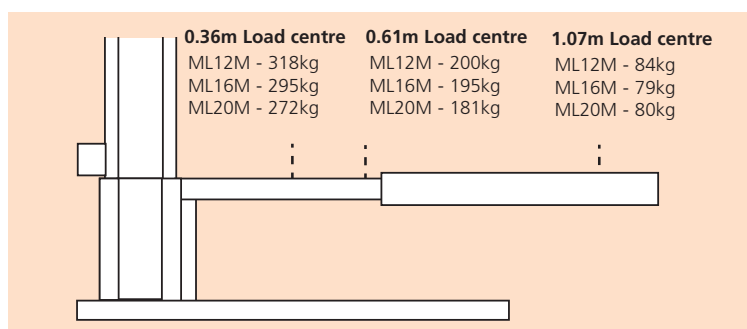

ML12M/ ML16M/ML20M

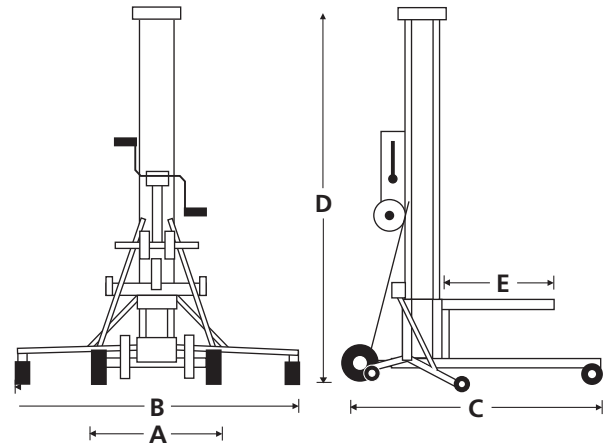

STANDARD FEATURES

- Stabilisers with non-marking swivel casters (ML12M)
- Non-marking transport/loading wheels
- Cable guard
- Mast brake
- Dual handle, two-speed shift-on-the-fly winch
- Metal cable pulleys with sealed bearings
- Heavy-gauge aluminium extrusions
- Heavy-duty, non-marking casters
- Quick-fold stabilisers
- Crane attachment point
- 2 year parts & labour, 5 year structural warranty
- CE approved

OPTIONS

- Special paint colours
- Adjustable forks
- Boom
- Pipe cradle
- Fork extensions
- Load platform
- Stabilisers with non-marking swivel casters (ML16M/ML20M)

snorkel www.snorkellifts.com

Vigo Centre, Birtley Road,
 Washington, Tyne & Wear,
 NE38 9DA, U.K.

t: +44 (0) 845 1550 057
 e: sales.emea@snorkellifts.com