



**BADLANDS**  
RANCH & RODEO EQUIPMENT

**LEGACY FOUNTAIN**

# OFFSET VALVE

The offset valve fountain provides more options in your pens or buildings for placement. Our standard foot prints provide an easy solution to swap out existing fountains without having to pour new concrete pads.

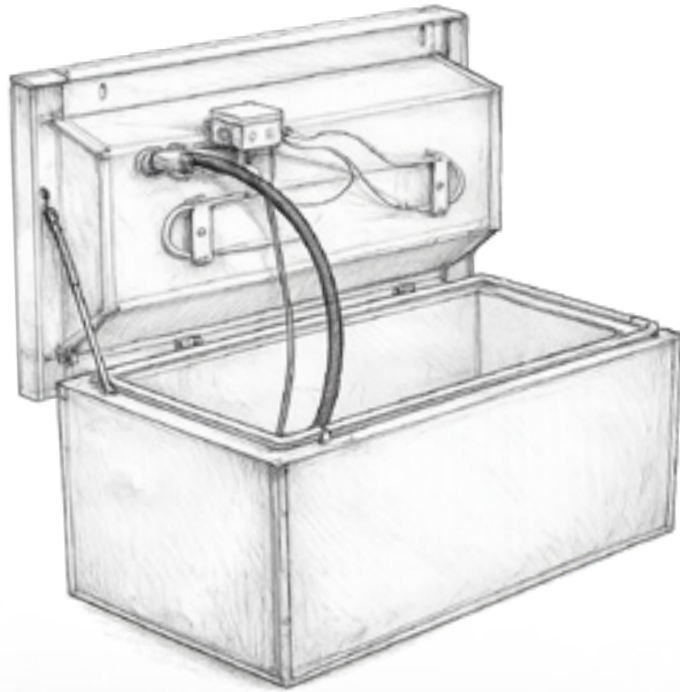

**LF-S1851**



**Capacity: 20 Gal**

Width - 24"
Length - 51"
Drinking Height - 18"
Herd Capacity
200 Beef - 100 Dairy

**LF-S1830**



**Capacity: 10 Gal**

Width - 22"
Length - 30"
Drinking Height - 18"
Herd Capacity
100 Horses - 100 Beef 50 Dairy

**LF-S1825**



**Capacity: 5 Gal**

Width - 18"
Length - 25"
Drinking Height - 18"
Herd Capacity
75 Beef - 35 Dairy 100 Sheep/Goat





# CENTERED VALVE

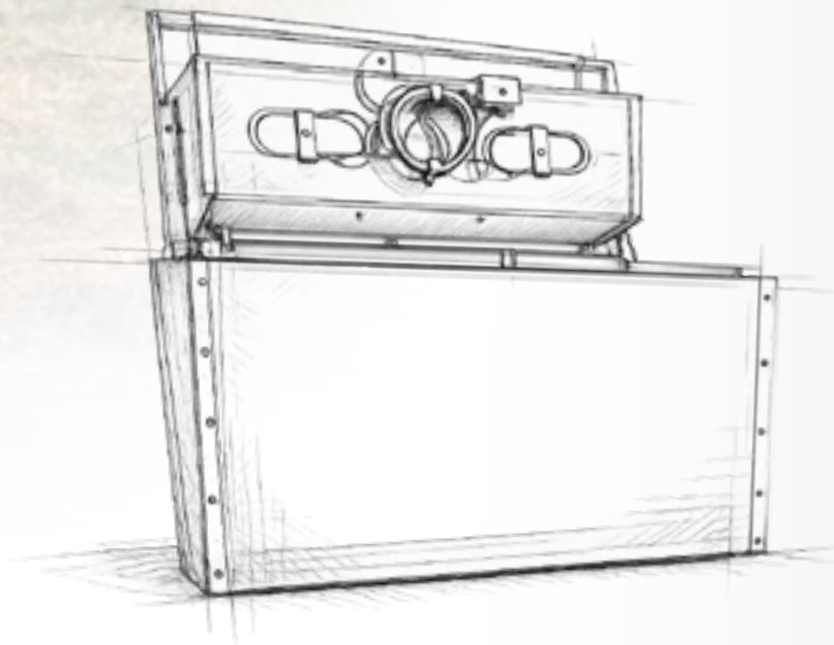

The center valve placement provides an easy option for splitting pens in a fence-line or on its own in your lots or barns. The centered valve and element placement provide additional protection from the elements while providing adequate water flow to your stock.

**LF-2648**



**Capacity: 28 Gal.**

Width - 24.75"
Length - 48"
Drinking Height - 26"
Herd Capacity
275 Beef - 135 Dairy

**LF-2636**



**Capacity: 16 Gal.**

Width - 24.75"
Length - 36"
Drinking Height - 26"
Herd Capacity
150 Horses - 150 Beef - 75 Dairy

**LF-2630**



**Capacity: 10 Gal**

Width - 22.75"
Length - 30"
Drinking Height - 26"
Herd Capacity
100 Beef - 50 Dairy

**LF-1830**



**Capacity: 10 Gal**

Width - 22.75"
Length - 30"
Drinking Height - 18"
Herd Capacity
100 Beef - 50 Dairy

## REPLACEMENT PARTS

For any other replacement parts please contact your local authorized Badlands dealer.

**W219**



Monticello Float and Valve Assembly  
- Standard 1/4" Orifice  
available in 1/8", 1/4" or .45"

**HE163**



Adjustable thermostat  
Factory set at 45 Degrees Fahrenheit

**HE119**



8' Heating Cable and tape to secure it to incoming water line

**HE115**



250W Heating Element



**THE MOST ACCESSIBLE  
FOUNTAIN ON THE MARKET**

# READY-TO-INSTALL DESIGN

The Legacy Fountains come with the following components installed from the factory for a fast install in the field.

- Heating Element(s)
- Float & Valve Assembly
- Supply Line Heat Tape
- Adjustable Thermostat
- Lift Assist Gas-Struts
- Weather-Stripping

Simply install and connect the below included components:

- Supply line extension hose with one brass fitting and hose clamps
- Connect power source to our pre-wired box.

Mount it to your concrete pad with your stainless steel anchor-bolts and you're ready for operation.



The Legacy Fountain line is engineered for producers who demand durability, easy access service, and reliable year-round performance.

- Flip-up trough design for easy maintenance
- Clear access to all components
- Rodent & Insect resistant foam insulation
- 9.5+ R-Value
- 3/4" valve with float
- Universal replacement parts
- Adjustable thermostat for cold-weather efficiency
- Heavy-duty stainless-steel construction
- Smooth, rounded edges for livestock safety

