

Assembly & Operator's Manual

TruckGator™

1,300 lbs Removable Liftgate



Visit our website at: www.liftgator.com

⚠ WARNING ⚠

Read the entirety of this manual before using the LiftGator. Failure to do so can result in serious injury or death.

SAVE THIS MANUAL

For questions or replacement parts, call (605) 753-0919.

Table Of Contents:

- Terms & Conditions
 - Warranty
- Diagram of Main Components of TruckGator
- Safety
 - General Safety Precautions & Warnings
 - LiftGator Safety Precautions & Warnings
- General Operation
 - Pre-Operation Safety Check
 - Product Installation and Removal
 - Lifting Operation
- Maintenance Procedures
 - Monthly and Six-Month Procedures
 - Charging Instructions
 - Lubrication Instructions
 - Connection Points
- Troubleshooting
 - Images for Reference

Terms & Conditions

GatorLiftgates, LLC. is hereby referred to as LiftGator. The purchaser, end-user, or installer is hereby referred to as user.

Legal Disclaimer:

- LiftGator's products must be assembled and maintained by a qualified professional as recommended by LiftGator.
- System operation and assembly is at the user's own risk. LiftGator accepts no liability for damage of property or persons caused by its products, components, accessories, installation/assembly instructions or otherwise.
- LiftGator accepts no responsibility for systems, products or components provided by other manufacturers for use with or around the LiftGator product. For components other than LiftGator's, follow the manufacturer's instructions for installation and operation.

LiftGator Warranty:

Your LiftGator liftgate is warranted to the original purchaser to be free from defects in material and workmanship for a period of one (1) year, except as herein limited, from the date of purchase. The obligations of Gator Liftgates, LCC (the Company) under this limited warranty shall be limited to repairing or replacing any part or parts which, in the opinion of the Company, shall be proved defective in materials or workmanship under normal use and service during the one-year-period commencing with the date of purchase. Paint is warranted to be free from defects in material and workmanship for a period of ninety (90) days from the date of purchase. Color fade and color differences are not warranted. This warranty does not cover any part or parts which have been damaged as a result of an accident, misuse, abuse, or which have been modified, altered or repaired by other than the Company. This warranty shall not apply if the lift gate has been subjected to loads in excess of its rated capacity. The remedies described herein are the sole remedies.

Limitations and Exclusions

- Warranties are to the original owner and are non-transferable.
- Equipment which has been modified, repaired, or altered in any way without the express written consent of the Company.
- Unreasonable use (including failure to provide reasonable and necessary maintenance).
- Equipment which is warranted separately by the respective manufacturers of said components.
- Parts not supplied by the Company.
- Parts which require replacement in the ordinary course of use due to normal wear.
- Any liftgate after 90 days from the date of purchase if the liftgate is utilized as a rental unit or as part of a rental combination with rental equipment.
- Damage to paint resulting from deterioration due to use or exposure, such as chipping, scratching or damage due to road salt, tar or pressure washing.
- Labor costs will not be reimbursed.

THE FOREGOING WARRANTIES ARE EXCLUSIVE AND THE REMEDIES PROVIDED THEREIN ARE THE SOLE AND ONLY REMEDIES. THERE ARE NO WARRANTIES, EITHER EXPRESSED OR IMPLIED INCLUDING THE IMPLIED WARRANTIES OF MERCHANTABILITY AND FITNESS FOR A PARTICULAR PURPOSE ARE EXPRESSLY DENIED.

EXCEPT AS MAY BE PROHIBITED BY LAW, THE COMPANY SHALL NOT BE LIABLE FOR INCIDENTAL OR CONSEQUENTIAL DAMAGES OF ANY KIND OR DESCRIPTION INCLUDING BUT NOT LIMITED TO LOSS OF TIME, PROFIT, INCONVENIENCE, LOSS OF USE, TOWING FEES, TELEPHONE CALLS OR COST OF MEALS OR LODGING.

The limited warranty provided above, subject to the described limitations and exclusions, gives you specific legal rights, and you may also have other rights which vary from state to state.

Common Parts

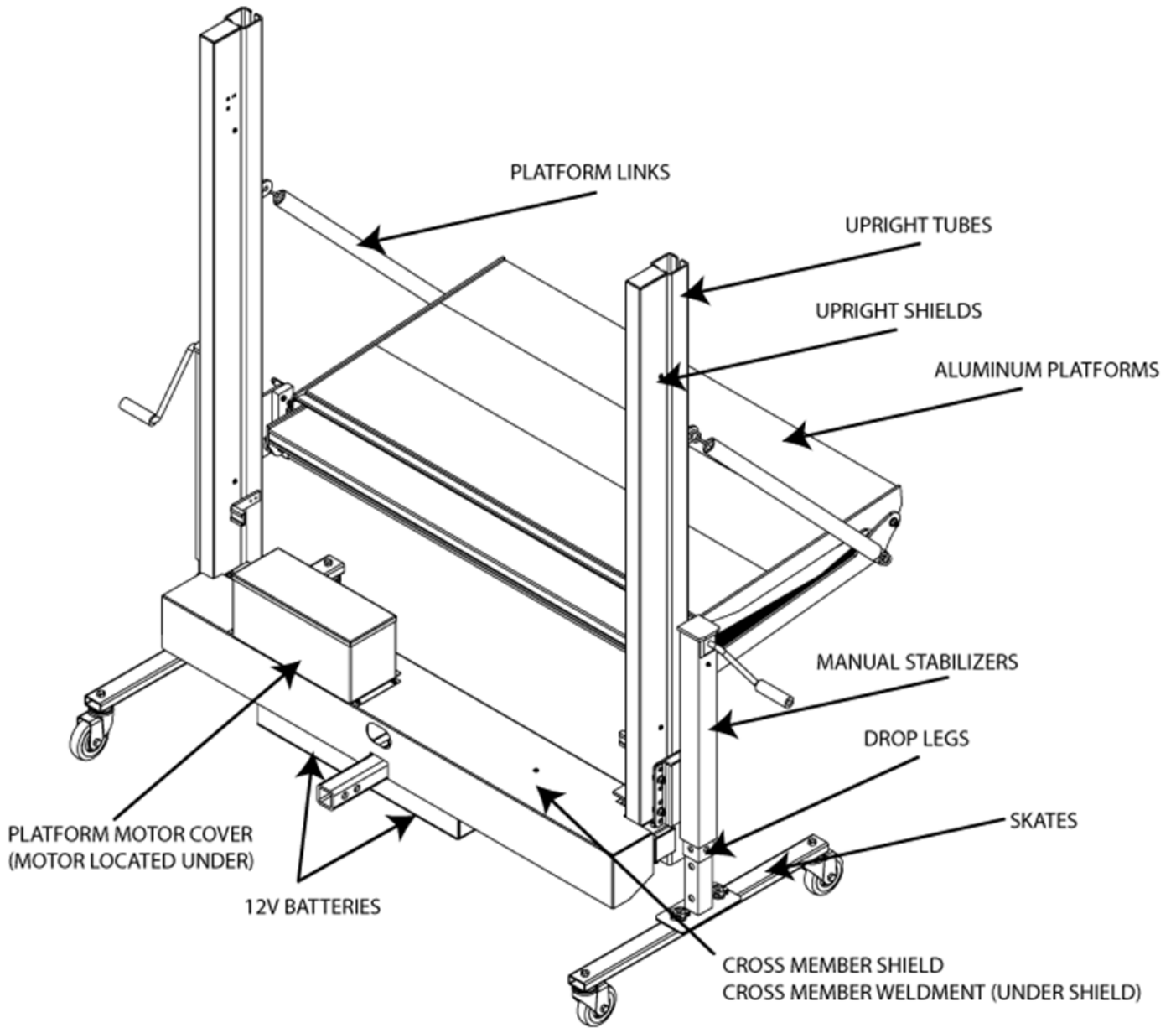

General Safety Precautions & Warnings

- Read the manual. Understand the entirety of this manual, all decals, and warnings before use. Failure to do so may result in serious injury or death.
- Keep children away. The LiftGator is an industrial product that is intended for use by adults only, no children should be allowed in the work area.
- When dismantled from the vehicle, store in a dry area to prevent rust.
- Check for damaged parts. Before using the LiftGator, thoroughly inspect all parts for damage, wear, alignments, binding, etc. If any part is damaged, discontinue use and seek assistance by a qualified technician.
- Only identical replacement parts shall be used during service. For parts and technical questions, call LiftGator. Any part that appears damaged should be repaired or replaced by a qualified technician.
- Do not operate under the influence of drugs or alcohol.
- A qualified technician shall perform all service and maintenance.
- Only use the LiftGator for its intended purposes, nothing else.

Decals



LiftGator Safety Precautions & Warnings

- The LiftGator is NOT intended for raising or lowering people.
- Liftgate hazards can result in crushing or falling.
- Never exceed the 1300-pound load capacity of the LiftGator.
- A class 3 hitch receiver or higher must be used in conjunction with the LiftGator.
- Always stay clear of the platform's path during lifting and lowering.
- Always drop the stabilizer legs completely to the ground and preload them before loading the lift. Be sure to lift and secure the stabilizer legs before driving the vehicle.
- The load shall always be placed as far forward as possible on the platform.
- Never lift objects that are hanging off the side of the platform. All unstable and rolling loads must be tied down before lifting and lowering with the LiftGator.
- Before dismounting, lower the platform to prevent likelihood of tip-over during transportation.
- Periodically clean all LiftGator parts of dirt and grime as well as lubricate necessary parts.
- Keep hands and feet clear of all potential pinch points.
- Discontinue use if the LiftGator shows signs of unusual noise, vibration, uneven lifting, or any sort of abnormal operation.
- All protective covers, guards, and safety devices must remain in place as intended by LiftGator.
- Always properly store and secure the LiftGator for transit. See 'General Operations' for details.
- Always secure cargo once in the vehicle's cargo bed.

General Operation

Pre-Operation Safety Check

Before each use, check the LiftGator for any physical damage, loose hardware, crimped wire rope, and deformed components. If during operation any unusual noises or vibrations occur, stop operation immediately and contact LiftGator customer support.

LiftGator Installation

Before installation of the LiftGator into the hitch receiver, it must be in the correct configuration. A skate must be fixed to the bottom of each stabilizer foot, the tailgate saver flap tucked underneath the platform flap, and the platform assembly folded and latched into the vertical position.

Watch video here for installation instructions.



1. On a flat, smooth surface, roll the LiftGator up to the vehicle's hitch receiver so the two long axes align.



WARNING: If transporting over uneven or tilted surfaces, be careful not to tip the LiftGator. Always keep the center of gravity low by lowering the platform before transporting.



2. If a height difference exists, raise, or lower the hitch by using the crank handle or the 7/16" driver provided on a drill to get the LiftGator hitch even with your hitch receiver by raising or lowering the stabilizer legs.
3. Slide the hitch into the hitch receiver until the holes align.
4. Once you feel like you have the LiftGator at the correct height, use a marker, tape, or something similar, to mark the height of the stabilizer legs. This will give you a quick reference to where your stabilizer legs need to be for easy installation and removal.
5. Roll the LiftGator into the hitch receiver and insert the hitch pin. Note: Clipped to the inside of the storage box will be a T-handle that you can use to insert and remove the hitch pin.
6. Using the crank handle, or the driver, tighten the hitch clamp bolt. This can be found inside the storage box, right on top of the LiftGator hitch. Note: Be careful to not over tighten the bolt.
7. If you used the T-handle, you should now be able to unscrew the handle from the hitch pin and place the T-handle back in the storage box.
8. Unscrew the wing nuts off the skate's threaded studs and place them closely to the side.
9. Use the handle, or driver, to retract the stabilizer leg until the weight of the LiftGator is removed from the skate.
10. Pull the stabilizer leg pin and slide it back up into its housing and re-pin it in the highest position; the skate will fall from the stabilizer bottom.
11. Continue to retract the stabilizer leg until the stabilizer leg is as high as possible for ground clearance.
12. Repeat steps 8-11 for the opposite stabilizer leg.
13. Ensure that the license plate is visible by raising or lowering the platform.

LiftGator Removal

1. Pull onto a hard, flat surface, such as concrete or asphalt, to remove the LiftGator.
2. Fold the platform into the vertical position with the tailgate saver flap tucked beneath the platform flap so that it is held in place by the platform flap's hanging weight.
3. Using the platform switch located on the passenger side upright, position the platform as low as possible while still allowing room to remove the hitch pin.
4. Loosen, but do not fully remove, the hitch tightener bolt inside the storage box.
5. Attach the skates to the underside of each stabilizer leg by poking the studs through the holes in the stabilizer foot and clamping them together with the wing nuts.
6. Holding the skate in place, pull the stabilizer leg pin and gently lower the skate to the ground. Pin the stabilizer back into place. Repeat for the opposite stabilizer.
7. Extend each stabilizer leg until the hitch begins to visibly lift within the hitch receiver.
8. Remove the hitch pin with the T-handle and place it inside the storage box.
9. Avoiding all pinch points, carefully grab the LiftGator's crossmember and roll the hitch out of the hitch receiver.
10. Carefully push the LiftGator into a place of storage, preferably indoors to avoid rusting and weathering.
11. It is recommended to lubricate all moving parts with white lithium grease or a light oil and to check for damage to cable upon every dismounting of the LiftGator. See "Maintenance Procedures and Scheduling" for a complete list of maintenance checks.

Lifting Operation

1. It is recommended that you install and uninstall the LiftGator on a hard, even surface such as asphalt or cement.
2. Before lowering the LiftGator, each stabilizer leg, **with skates DETACHED**, must be deployed to the ground by pulling the stabilizer pin, dropping the leg, and resetting the stabilizer pin. Preload each stabilizer by extending the leg using the handle or the driver until resistance can be felt or you see the weight of the LiftGator being taken off the hitch.
3. Using the auto latch found on the right side of the platform, unfold the platform center to the horizontal position and the platform down.
4. Locate the platform switch on the upright “down” button until the platform meets the ground.

Note: The tailgate saver flap will automatically fold to the vertical position when the platform is lowered.

5. Carefully transfer the load from the ground onto the LiftGator’s platform. Ensure the load is centrally located on the platform and as far forward, towards the hitch, as possible.

WARNING: Taller objects run the risk of falling from the platform and causing serious injury, or even death.

6. Keeping clear of the platform’s path, raise the platform until the tailgate saver flap is horizontal to the vehicle’s cargo bed.
Note: The tailgate saver flap will automatically fold to the horizontal position when the platform is lifted from the ground.
7. Transfer the load from the platform to the bed of your truck.
8. Rotate the tailgate saver over the platform center, fold the cart stop flap over the tailgate saver, and fold the platform center to the vertical position. Push the platform towards the vehicle to securely latch the platform into position.
9. Adjust the platform height using the platform switch until the tailgate saver flap is horizontal to the cargo bed and the vehicle license plate is clearly visible to a driver in the rear.
10. Retract drop legs and secure the pins.

Lowering Operation

1. It is recommended that you load and unload the LiftGator on a hard, even-surface such as asphalt or cement.
2. Before lowering the LiftGator, each stabilizer, **with the skates DETACHED**, must be deployed to the ground by pulling the stabilizer pin, dropping the leg, and resetting the stabilizer pin. Preload each stabilizer by extending the leg using the handle or drill bit until resistance can be felt or you see the weight of the LiftGator being taken out of your hitch.
3. Using the auto latch found on the right side of the platform, unfold the platform center to the horizontal position and rotate the cart stop flap 180 degrees to extend the platform.
4. Locate the platform switch behind the passenger side stabilizer and press the “down” or “up” button until the tailgate saver flap rests horizontally on the cargo bed.
5. Carefully transfer the load from the cargo bed onto the LiftGator’s platform. Ensure the load is centrally located on platform center and as far forward, towards the hitch, as possible.
WARNING: Elevated objects run the risk of falling from the platform and causing serious injury, or even death. Use tie downs to fasten the load to the platform to decrease the chances of injury.
6. Keeping clear of the platform’s path, lower the platform all the way to the ground. Note: the tailgate saver flap will automatically fold to the vertical position when the platform is lowered.
7. Transfer the load off the platform.
8. Raise the platform and rotate the tailgate saver flap on top of the center platform. Rotate the cart stop flap over the platform center and tailgate saver flap, fold the platform center to the vertical position, and press the platform towards the vehicle to securely latch the platform into position.
9. Adjust the platform height using the platform switch until the tailgate saver flap is horizontal to the cargo bed and the vehicle license plate is clearly visible to a driver in the rear.
10. Retract the drop legs and secure pins.

Maintenance Procedures

A qualified technician shall perform all service and maintenance to the LiftGator. For more information, please call LiftGator.

Monthly Procedures

1. Check for damage to lifting structure such as bent/misaligned members or cracked welds possibly resulting from misuse.
2. Check that all pins, bolts, and fasteners are tight and secure.
3. Check for worn or damaged bearings, pivoting points, pulleys, and cables.
4. Check that all controls operate properly.
5. Check ALL electrical wires and connections. They must be tight and free of corrosion.
6. Check that the platform auto latch secures the platform in a safe transport position.
7. Check lubrication of all pulleys, cables, and winch - refer to "Lubrication Instructions".

6-Month Procedures

1. Perform all "Monthly Procedures."
2. Check that all decals are in place and legible. Call LiftGator for decal ordering instructions.
3. Inspect winch for wear and damage.

Charging Instructions

1. Each unit we send out will have a Duracell charger included. There will be a red and black cable with a connection point alongside the 7-pin cable where you can plug in the Duracell charger.
2. We recommend that anytime the LiftGator is off a vehicle, it is stored inside, near an outlet, and plugged in so that the batteries will remain charged.
3. If the batteries read below 12.1v, please charge them to full before using.
4. Like any ATV or small battery machine, if your LiftGator is not used for an extended period, and has not been plugged in, you could see a drain on the batteries' charge.



Lubrication Instructions

The LiftGator should be lubricated every 3 months. Using a lightweight machine oil or white lithium grease, lubricate all the pivoting and rubbing joints on the LiftGator, including:

- Front Flap and Kick Flap pivoting hinges.
- Pivot points between the two carriers and platform center.
- Entire length of both wire ropes (white lithium grease).
- Run the LiftGator through a full cycle (up and down) while lubricating the wire rope as it cycles through the upper pulleys, lower pulleys, and winch clamp.
- Upper pulleys, lower pulleys, and tensioner pulley pivot points.



Lubrication Areas

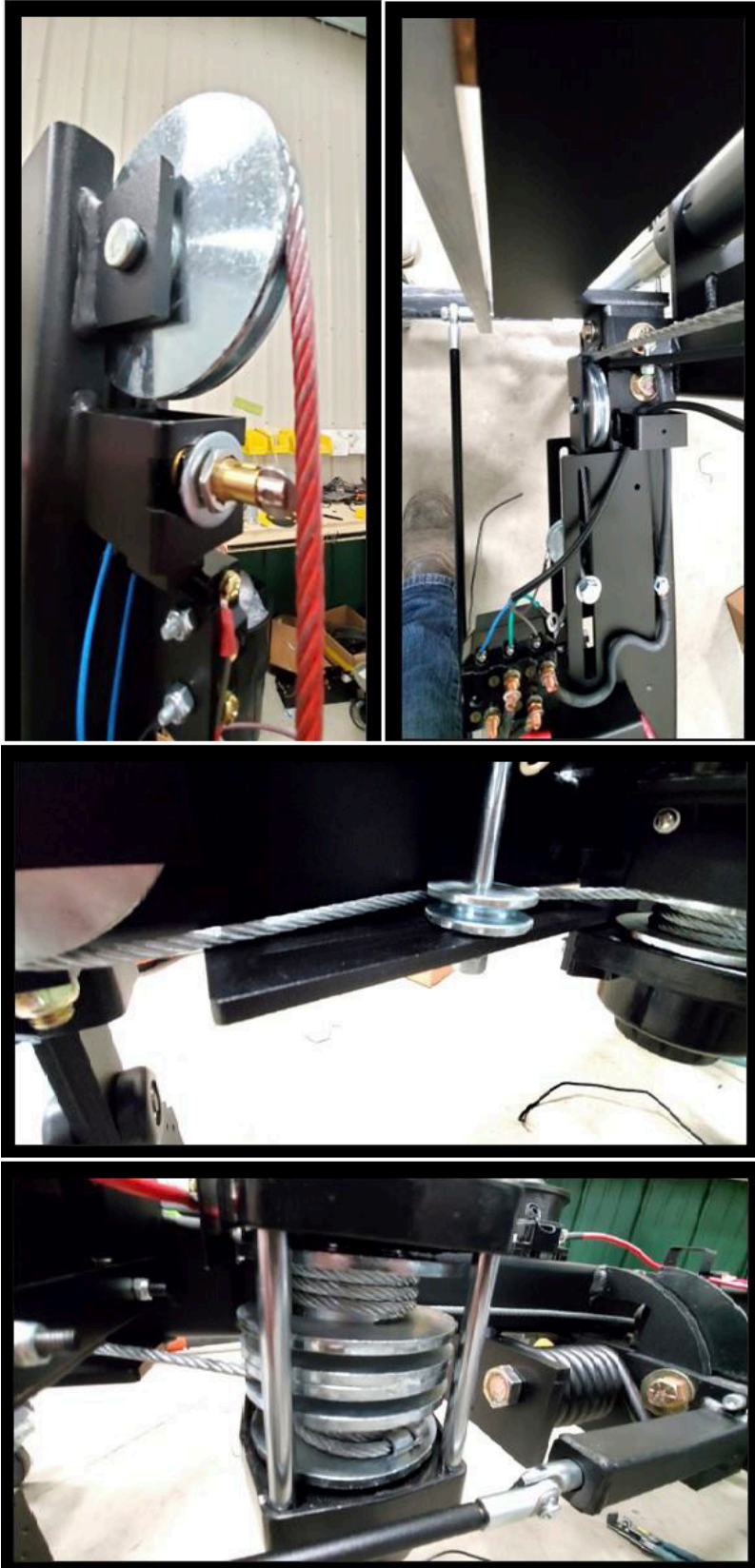

Connection Points

Check all electrical connection points. If there is rust or corrosion DO NOT use the unit. Please contact LiftGator Service for new parts. Examples below:

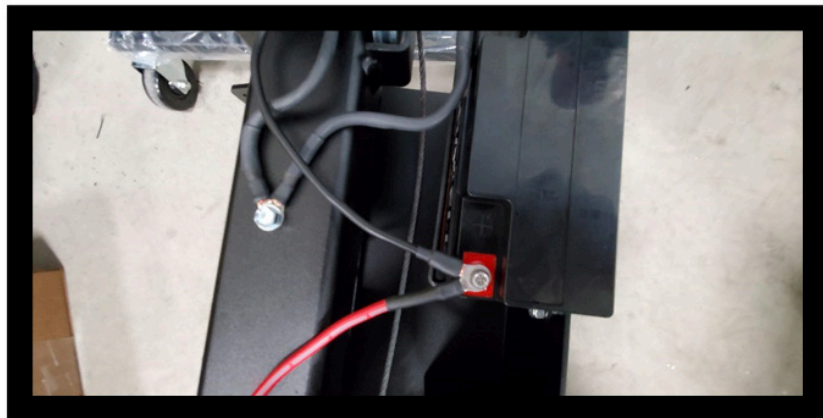
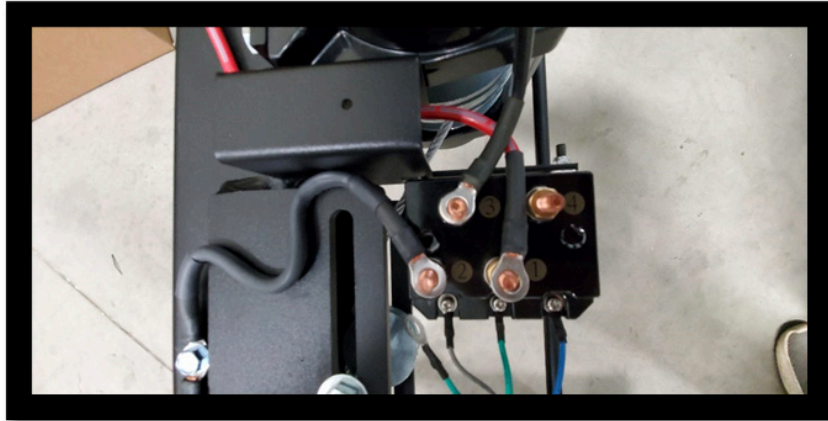

Troubleshooting Potential Issues

Issue	What Might be Wrong	Possible Fix
Platform switch will not work	Poor connection	Check to ensure the batteries are fully charged (13.1V), and that all wiring connections are in good standing. If batteries are drained, change or replace them. Image 1 for reference.
Platform does not raise or lower	Platform winch motor may be inoperable. The platform being used with low batteries can cause damages to the winch motor.	If the platform switch appears to be working, the batteries are fine and your platform still will not raise or lower, check to ensure that enough voltage is getting to the platform motor. Image 2 for reference.
Platform works intermittently	Bad solenoid	Make sure that the connections and wiring going to the solenoid is intact and in good condition. Image 3 for reference
Platform will not go down or chatters	Upper slack out switch not engaged	Check to make sure that the upper slack out switch (directly below the pulley on the passenger side) is engaged correctly. It should have a plastic guide on it to trigger the switch. Image 3 for reference

Reference Images

Image 1

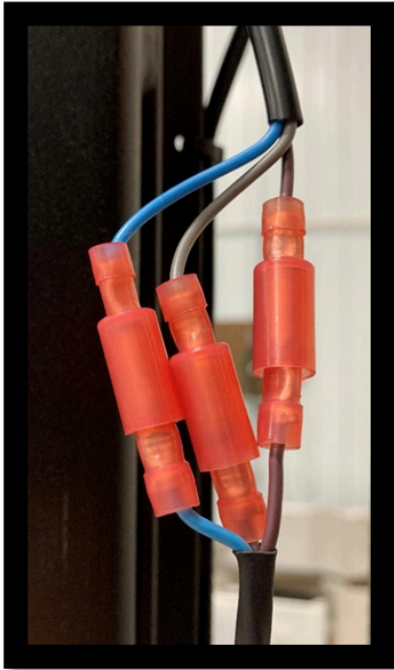

Image 2



Image 3

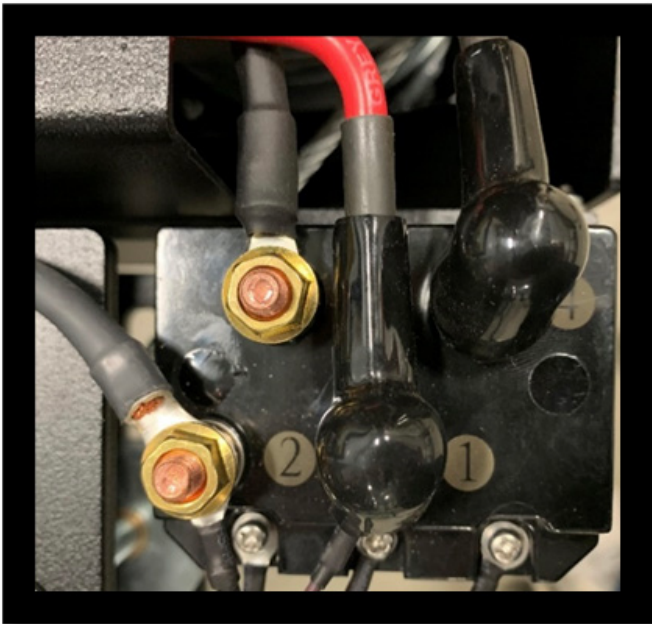

Image 4

