

## **SERIES**

# LCD SMART SWITCH

## L8 Is a Complete Smart Home System

L8 series includes five-in-one switch / Smart dimmer / Smart thermostat / Smart water heater / Smart socket / Smart IR repeater (controller such as air conditioner TV) / You can easily build a complete smart home.



L8-HS (1/2/3 gang light switch, Curtain switch, Scene switch)



EU standard-White



EU standard-Black



US standard-White



US standard-Black

### Wiring Diagram

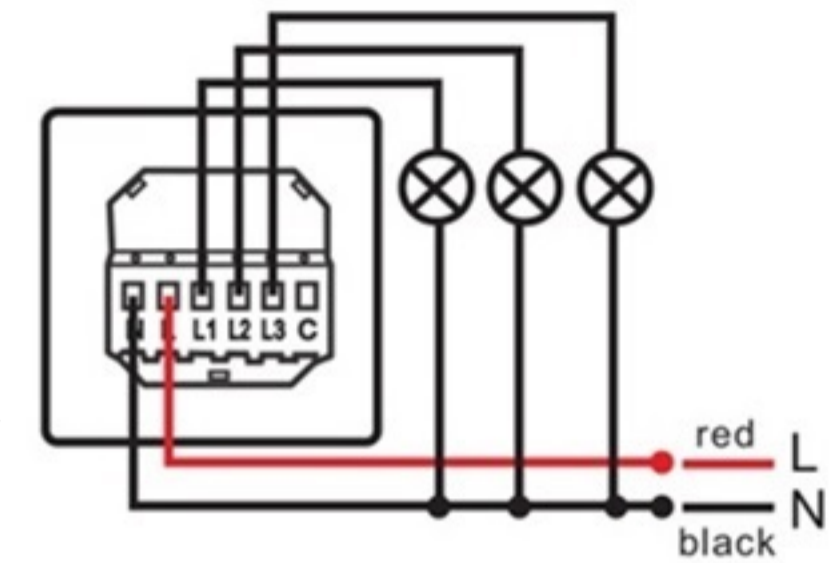

### Size Diagram

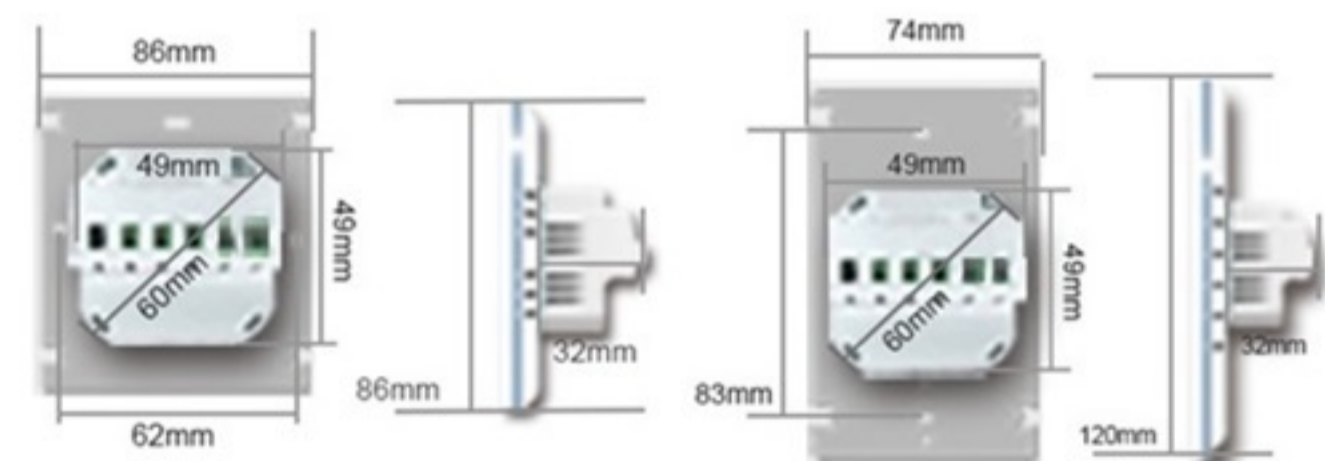

### Package



### PRODUCT PARAMETERS

SIZE:	86×86mm/120×74mm
ITEM NO:	L8-HS
WEIGHT:	0.3kg
PACKING BOX SIZE:	102.6mm*141mm*51.1mm
PANEL:	Capacitive touch screen
BOTTOM MATERIALS:	Retardant PC
RATED VOLTAGE:	AC 100-250V 50/60Hz
RATED LOAD:	200W
LOAD TYPE:	INCANDESCENT LAMP, ENERGY SAVING LAMP, FLUORESCENT
WIRELESS STANDARDS:	IEEE 802.11b/g/n
FREQUENCY RANGE:	2.405GHz~2.480GHz
RECEIVING SENSITIVITY:	-97dBm@250kbps
OPERATING TEMPERATURE:	-25 °C +60 °C
RELATIVE HUMIDITY:	<95%

## L8-HD ( LCD Dimmer switch )



EU standard-White



EU standard-Black



US standard-White



US standard-Black

### Wiring Diagram

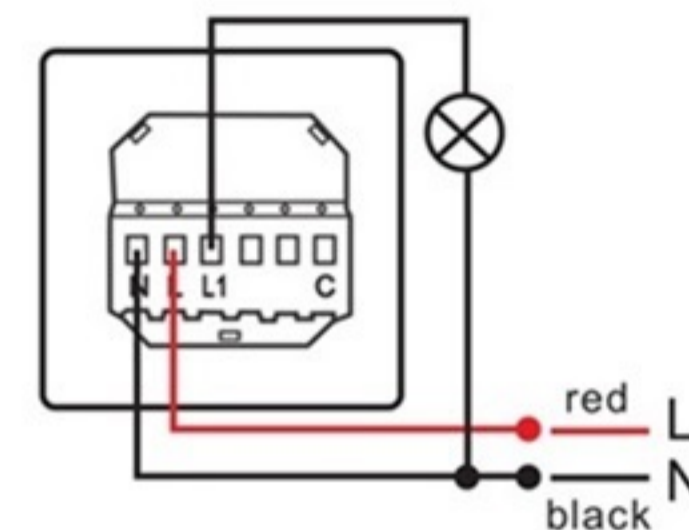

### Size Diagram

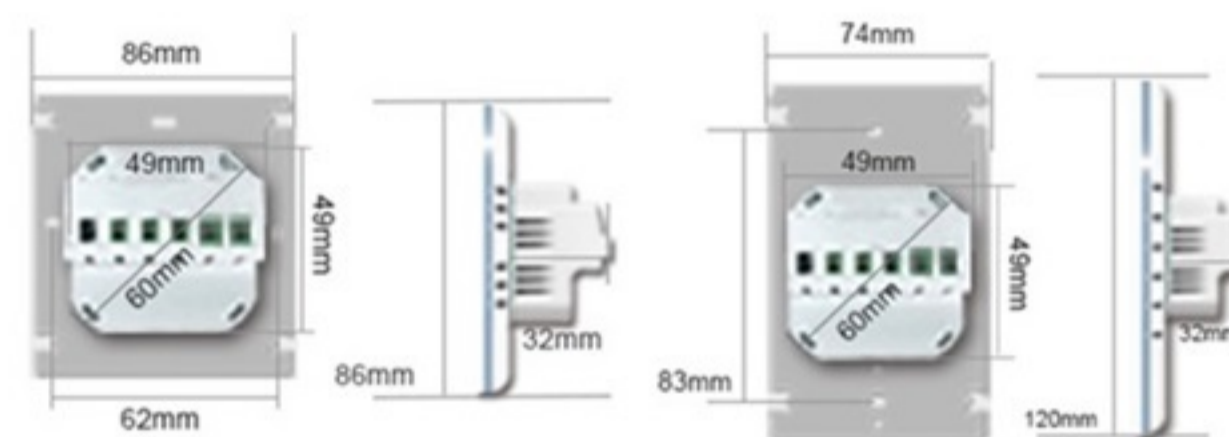

### Package



### PRODUCT PARAMETERS

SIZE:	86×86mm/120×74mm
ITEM NO:	L8-HD
WEIGHT:	0.3kg
PACKING BOX SIZE:	102.6mm*141mm*51.1mm
PANEL:	Capacitive touch screen
BOTTOM MATERIALS:	Retardant PC
RATED VOLTAGE:	AC 100-250V 50/60Hz
RATED LOAD:	100W
LOAD TYPE:	Incandescent lamp , LED lamp
WIRELESS STANDARDS:	IEEE 802.11b/g/n
FREQUENCY RANGE:	2.405GHz~2.480GHz
RECEIVING SENSITIVITY:	-97dBm@250kbps
OPERATING TEMPERATURE:	-25 °C +60 °C
RELATIVE HUMIDITY:	<95%

## L8-HT ( LCD Thermostat switch )



EU standard-White



EU standard-Black



US standard-White



US standard-Black

### Wiring Diagram

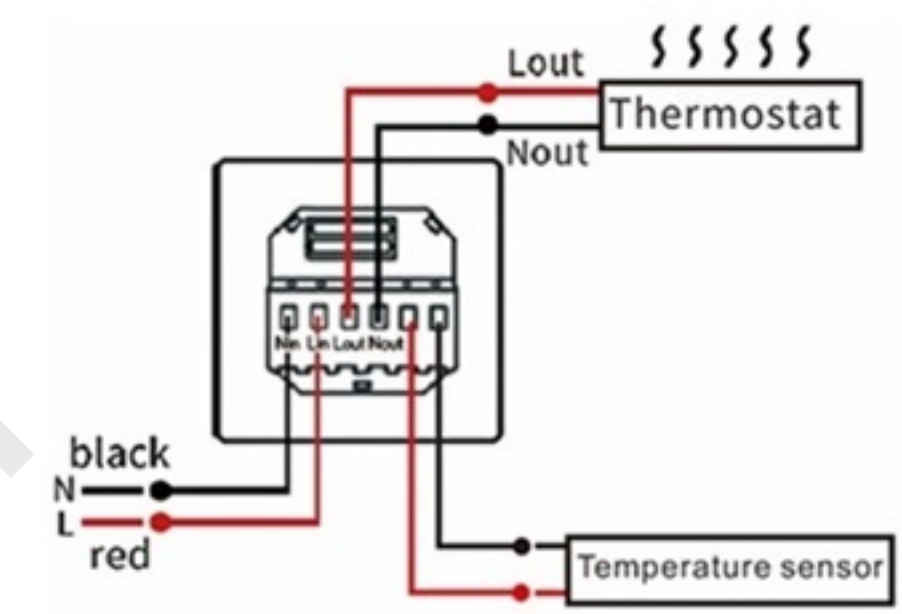

### Size Diagram

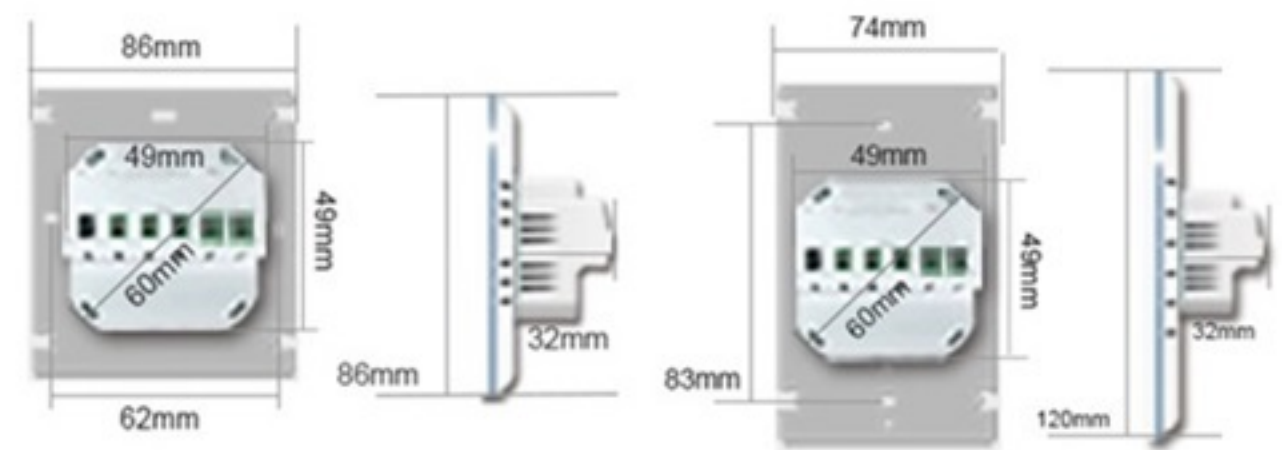

### Package



### PRODUCT PARAMETERS

SIZE:	86×86mm/120×74mm
ITEM NO:	L8-HT
WEIGHT:	0.3kg
PACKING BOX SIZE:	102.6mm*141mm*51.1mm
PANEL:	Capacitive touch screen
BOTTOM MATERIALS:	Retardant PC
RATED VOLTAGE:	AC 100-250V 50/60Hz
RATED LOAD:	16A
LOAD TYPE:	Floor heating
WIRELESS STANDARDS:	IEEE 802.11b/g/n
FREQUENCY RANGE:	2.405GHz~2.480GHz
RECEIVING SENSITIVITY:	-97dBm@250kbps
OPERATING TEMPERATURE:	-25 °C +60 °C
RELATIVE HUMIDITY:	<95%

## L8-HB ( LCD Boiler switch )



EU standard-White



EU standard-Black



US standard-White



US standard-Black

### Wiring Diagram

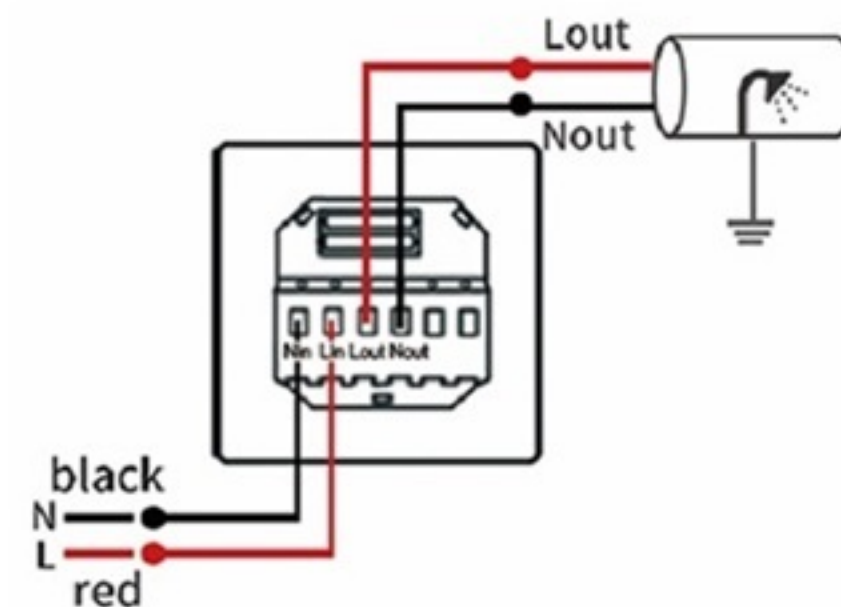

### Size Diagram

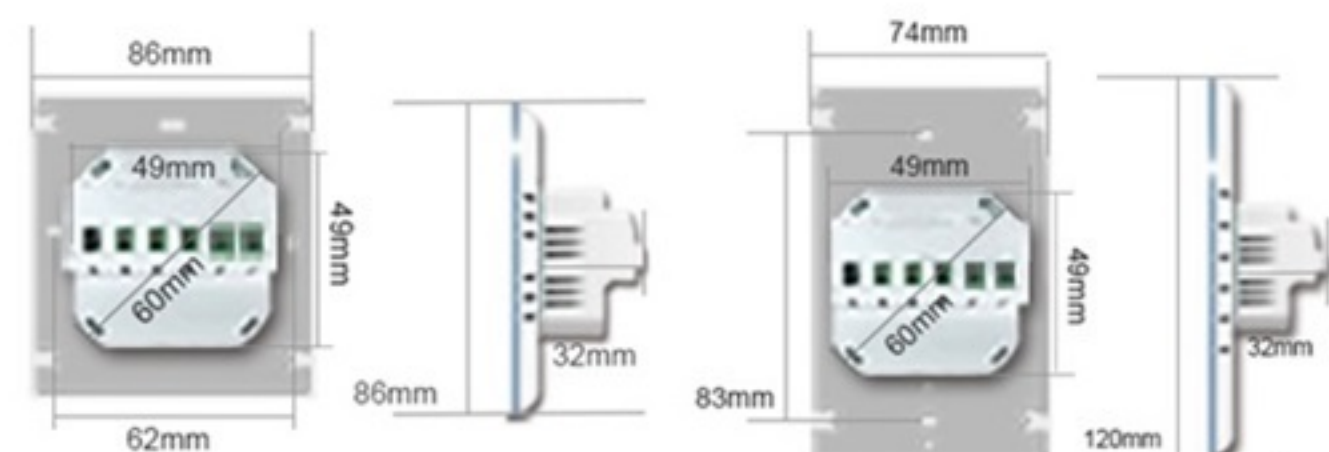

### Package



### PRODUCT PARAMETERS

SIZE:	86×86mm/120×74mm
ITEM NO:	L8-HB
WEIGHT:	0.3kg
PACKING BOX SIZE:	102.6mm*141mm*51.1mm
PANEL:	Capacitive touch screen
BOTTOM MATERIALS:	Retardant PC
RATED VOLTAGE:	AC 100-250V 50/60Hz
RATED LOAD:	16A
LOAD TYPE:	No limited for water heater brand
WIRELESS STANDARDS:	IEEE 802.11b/g/n
FREQUENCY RANGE:	2.405GHz~2.480GHz
RECEIVING SENSITIVITY:	-97dBm@250kbps
OPERATING TEMPERATURE:	-25 °C +60 °C
RELATIVE HUMIDITY:	<95%

## L8-HR ( Smart IR Repeater )



front



side

## Wiring diagram

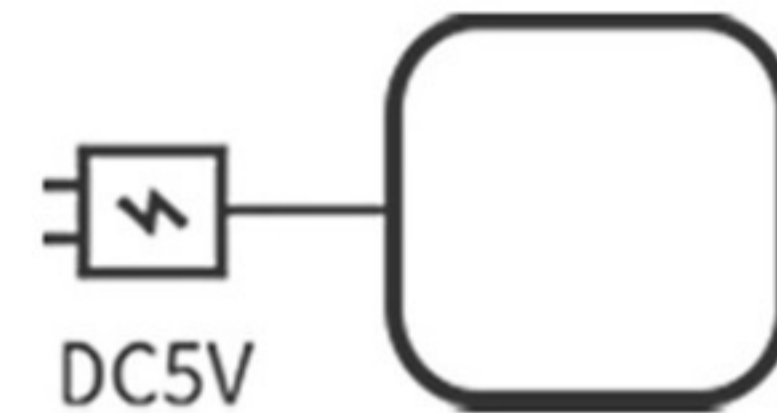

## Size diagram



## Package



## PRODUCT PARAMETERS

SIZE:	105X105X27MM
ITEM NO:	L8-HR
WEIGHT:	0.3KG
PACKING BOX SIZE:	170×135×47MM
MATERIALS:	ABS
RATED VOLTAGE:	DC 5V
STANDBY POWER:	0.5W
LOAD TYPE:	ALL APPLIANCES WITH INFRARED REMOTE
WIRELESS STANDARDS:	IEEE 802.11B/G/N
FREQUENCY RANGE:	2.405GHZ~2.480GHZ
RECEIVING SENSITIVITY:	-97DBM@250KBPS
OPERATING TEMPERATURE:	-25 °C +60°C
RELATIVE HUMIDITY:	<95%

## L8-HK1 ( Smart Door Lock )



## Size diagram



## Package



## PRODUCT PARAMETERS

Product name	WIFI Fingerprint smart door lock
Product model	L8-HK1
Power type	DC 6V
Working current	DC 6V, open & close 20,000 times regularly
Battery type	4 AA battery
Material	Zinc alloy
Apply range	Wooden door/Steel door/Copper door/Composite door/Anti-theft door
Size	Door thickness 40-60mm
Function	Fingerprint/Password/Smart living App/Induction/Key
Password length	6-8 bits, 16-bit garbled function

L8-HLS ( WIFI Mesh Smart RGB Color Light Strip )

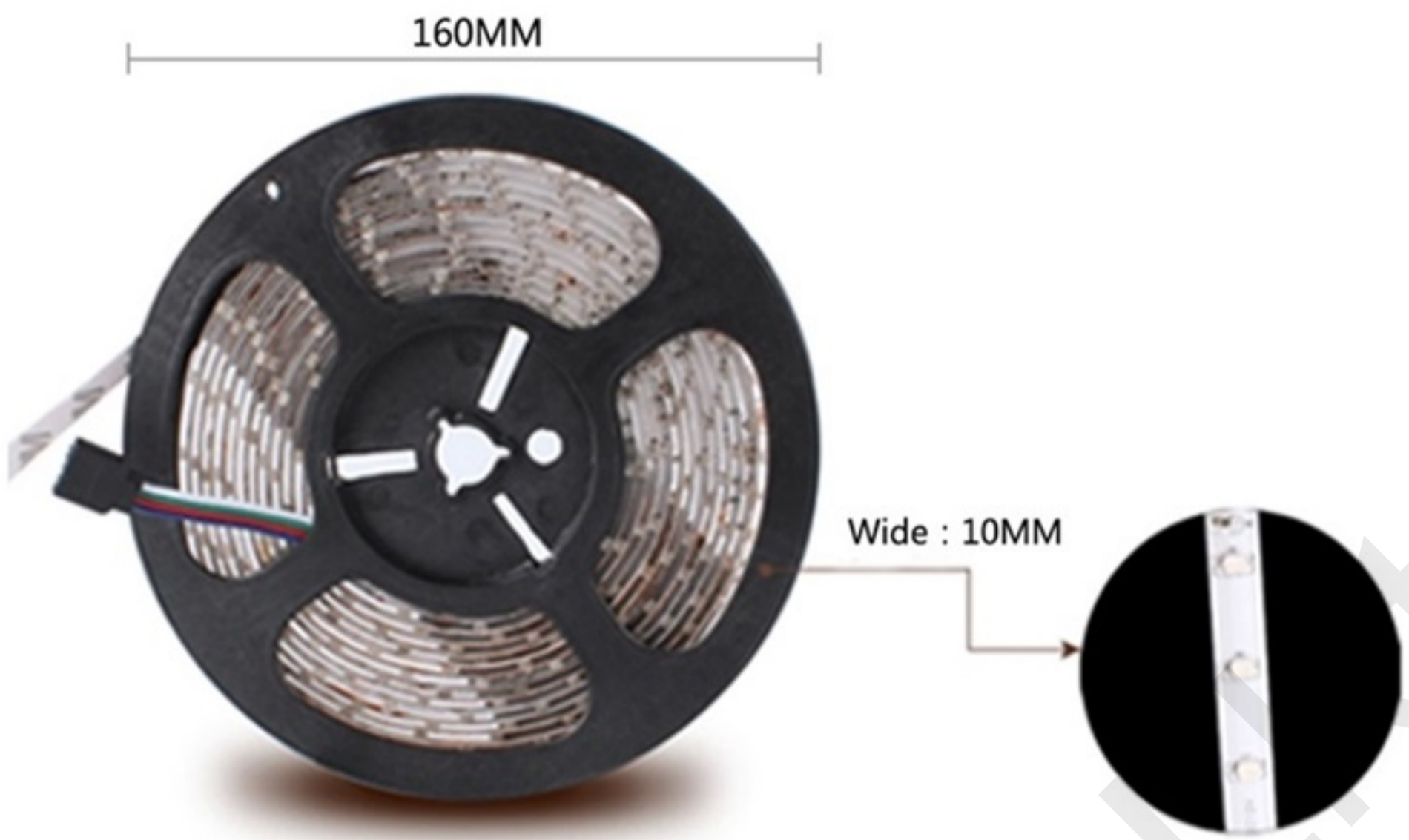

### Wiring diagram

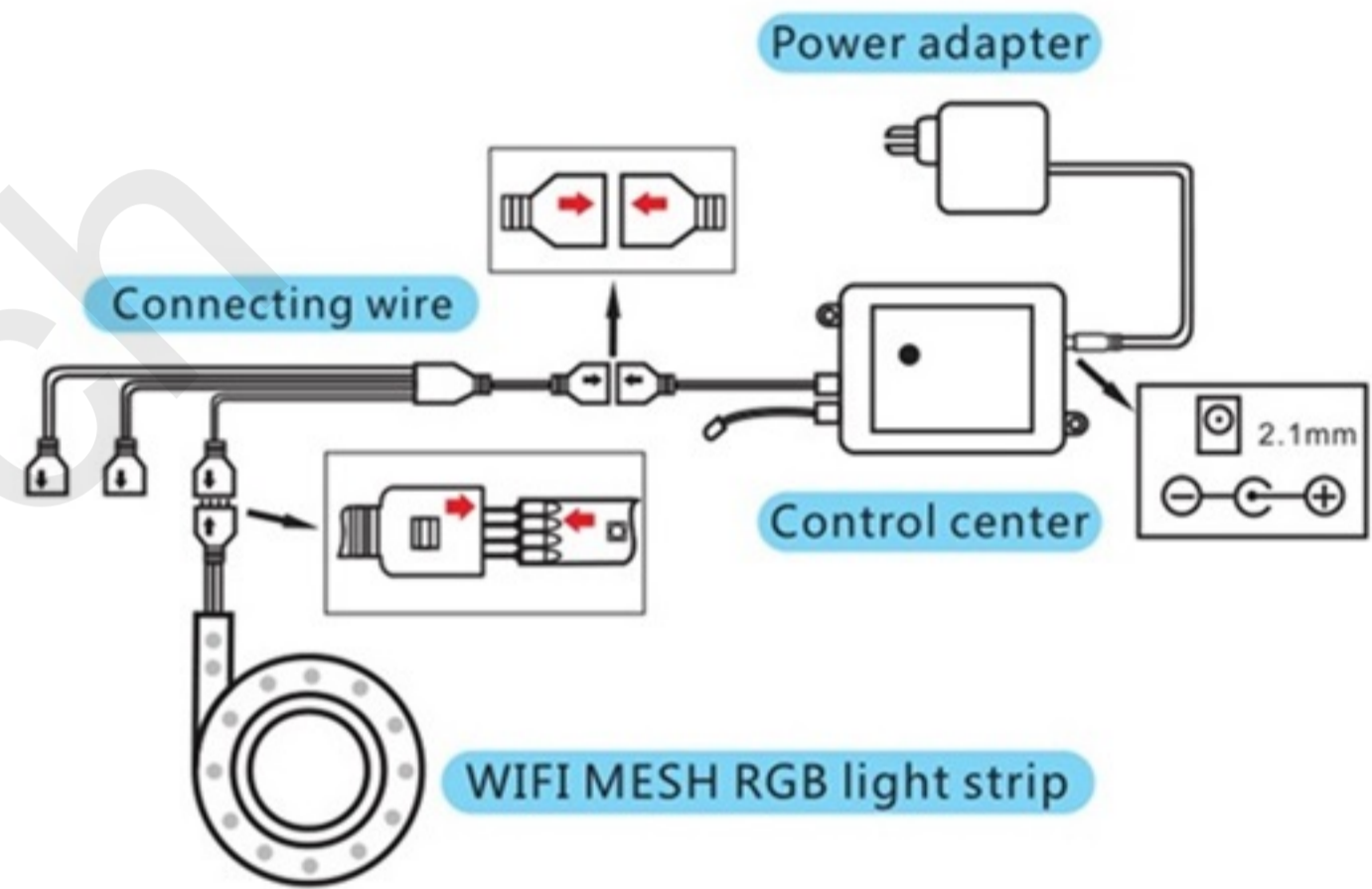

### Package



### PRODUCT PARAMETERS

Name	RGB Light Strip	Lumen/Luminous Flux	20Lm/PCS
Model	L8-HLS	Working Temperature	-26°C-65°C
Power	60W	Lamp beads size	5050
Working Voltage	DC12V	Light strip size	5M*300PCS*2
Per box size	50x38x36CM	Weight per case	20KG
Each set of size	17.5x6.5x16.5CM	Weight per set	0.7KG
Adapter type	UK type, EU type,US type, AU type		



L6-AC360H、L6-ARV360、L6-ARI360、L6-AR4 ( Smart Colorful Outdoor Camera )



L6-ARV360



L6-ARI360



L6-AC360H



L6-AR4

### Size diagram



### Package



SIZE:	190x57mm
ITEM NO:	L6-AC360H、L6-ARV360、L6-ARI360、L6-AR4
VIEW ANGLE:	360°/180°
INPUT VOLTAGE:	D
IMAGE SENSOR:	HD720PH/960PH/1080PH
STORAGE MEDIA:	Micro SD(UP to 128G)
MINIMUM ILLUMINATION:	0.01LUX@F2.0,BLACK/WHITE 0.001LUX@F2.0
NETWORK SETTINGS:	AP MODE/STAION MODE
MOBILE WIFI VIDEO:	HD 720P/960P/1080P/VGA
AUDIO CODING:	ADPCM TWO WAY VOICE INTERCOM
WIRELESS STANDARDS:	IEEE 802.11b/g/n

L8-HOU



US standard-White



## Wiring Diagram

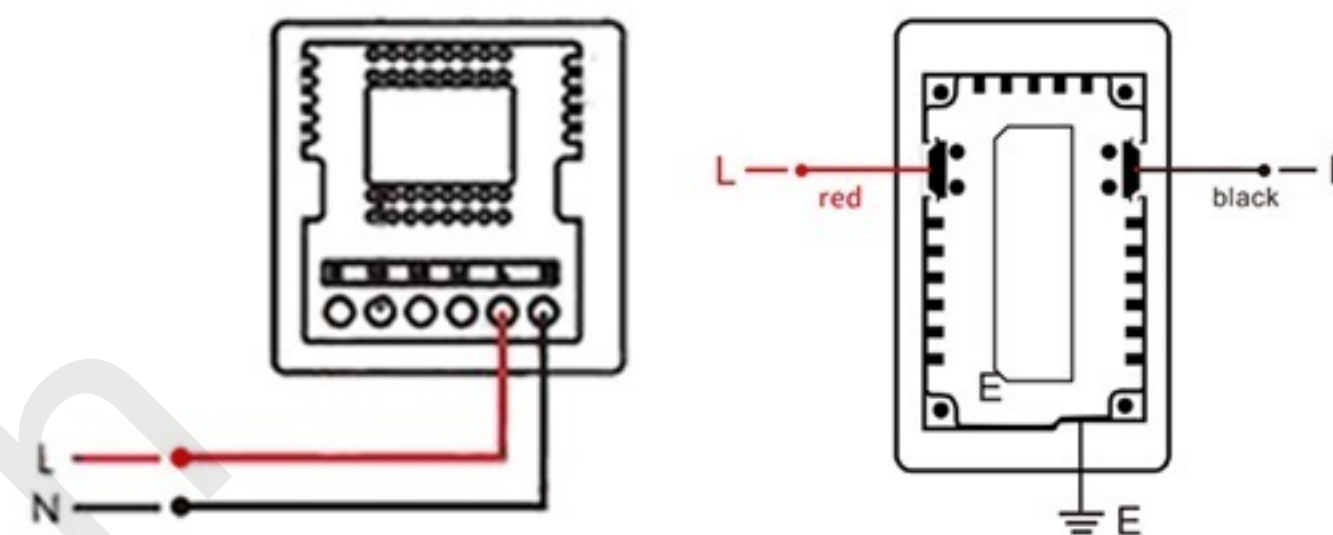

## Size Diagram

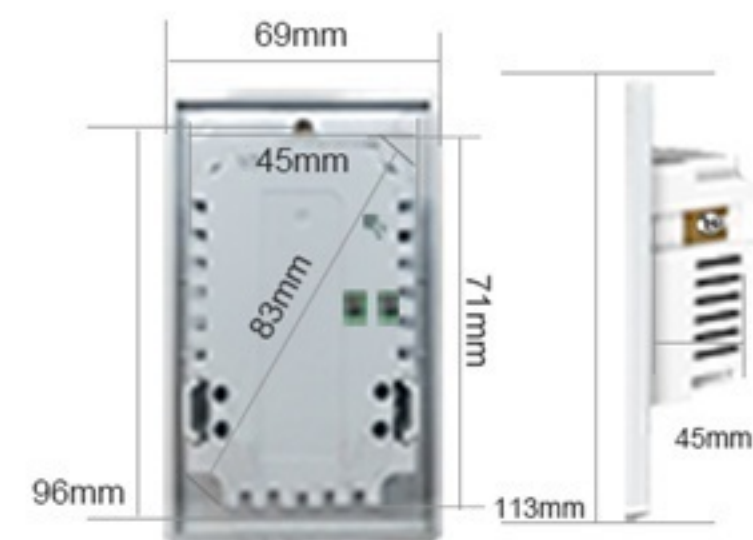

## Package



## PRODUCT PARAMETERS

SIZE:	86×86mm/113×69mm
ITEM NO:	L8-HOP、L8-HOU
WEIGHT:	0.3kg
PACKING BOX SIZE:	102.6mm*141mm*51.1mm
PANEL:	Capacitive touch screen
BOTTOM MATERIALS:	Retardant PC
RATED VOLTAGE:	AC 100-250V 50/60Hz
RATED LOAD:	16A
LOAD TYPE:	No limited
WIRELESS STANDARDS:	IEEE 802.11b/g/n
FREQUENCY RANGE:	2.405GHz~2.480GHz
RECEIVING SENSITIVITY:	-97dBm@250kbps
OPERATING TEMPERATURE:	-25 °C +60 °C
RELATIVE HUMIDITY:	<95%

L8-AG ( WIFI Mesh Gas alarm sensor )



British regulations



American regulations



European regulations

Size Diagram



## PRODUCT PARAMETERS

SIZE:	69×121mm
ITEM NO:	L8-AG
WEIGHT:	130g
PACKING BOX SIZE:	88mm*124mm*74mm
RATING POWER:	3W
RATED VOLTAGE:	AC 100-240V 50/60Hz
DETECTING GAS:	LPG,natural gas, and coal gas
SOUND LEVEL:	≥85dB/m
ALARM LEVEL:	10±3%LEL
OPERATING TEMPERATURE:	-10°C+50°C
RELATIVE HUMIDITY:	<95%

Package



## L8-HM (WIFI Mesh Smart Module )

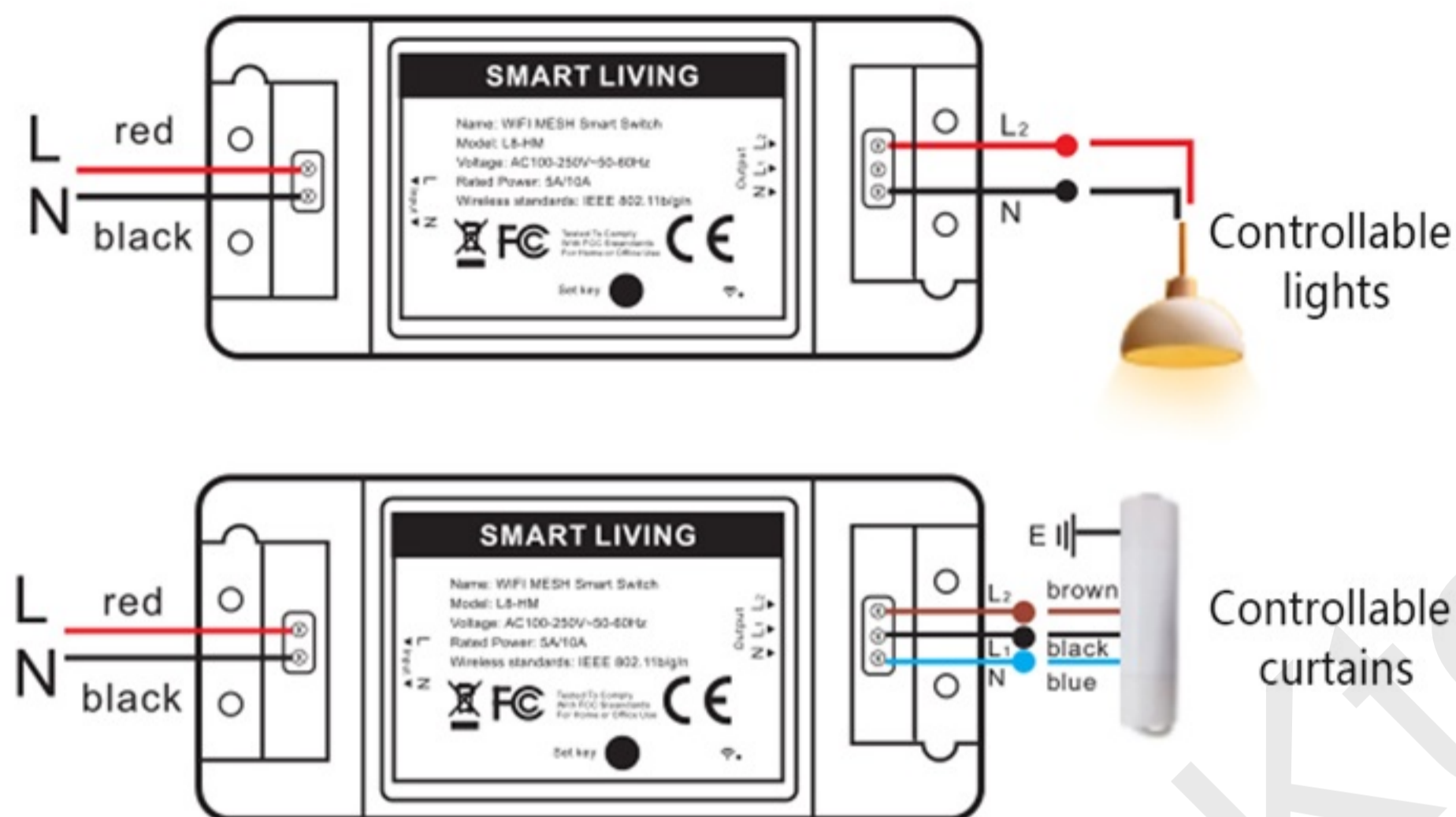

## Size Diagram



## PRODUCT PARAMETERS

SIZE:	88×38x23.5mm
ITEM NO:	L8-HM
WEIGHT:	0.15kg
WEIGHT PER CASE:	15kg
EACH SET OF SIZE:	90mm*30mm*45mm
PER BOX SIZE:	490mm*370mm*40mm
BOTTOM MATERIALS:	Retardant PC
RATED VOLTAGE:	AC 110-250V 50/60Hz
WIRELESS STANDARDS:	IEEE 802.11b/g/n
FREQUENCY RANGE	2.405GHz~2.480GHz
RECEIVING SENSITIVITY:	-97dBm
OPERATING TEMPERATURE:	-25 °C +60 °C
RELATIVE HUMIDITY:	<95%

## Package

